



# Specification

|                 |                   |
|-----------------|-------------------|
| <b>Product</b>  | <b>LED BULB</b>   |
| <b>Part No.</b> | <b>NS-A60-A5</b>  |
| <b>Date</b>     | <b>2012.10.10</b> |
| <b>Version</b>  | <b>V1.0</b>       |

|  |              |                |
|--|--------------|----------------|
| <b>Foshan NationStar Optoelectronics Co., Ltd.</b> |              |                |
| <b>LED Lighting Branch</b>                         |              |                |
| <b>DRAFT</b>                                       | <b>CHECK</b> | <b>CONFIRM</b> |
|  |              |                |



# NS-A60-A5

## 1. Product Features:

1. Environmental friendly, no stroboflash ,no UV or IR
2. High energy-efficiency. it can replace 40W incandescent lamp,
3. Good quality LEDs, long lifespan,
4. Easy installation, compatible with traditional socket E27,
5. Unique optical design, uniform and soft light output,
6. Insulated ceramic materials with high thermal conductivity adopted, better heat dissipation performance, better stability and avoid the electric shock.

## 2. Application

Widely used in office, office building, administrative office hall, shopping mall, stores, specialty store, libraries, museums, hotels and restaurants.

## 3. Electro-Optical Characteristics:

### ● Electrical Parameter for Non-Dimmable Series :

| Parameter         | Value      | Unit   |
|-------------------|------------|--------|
| Input voltage     | AC110—240V | V      |
| Power factor      | ≥0.5       | -      |
| Frequency         | 50/60      | Hz     |
| Illuminant        | TOP LED    | -      |
| Luminous flux     | 300        | Lm     |
| Color temperature | 3000~6500  | K      |
| CRI               | 70~80      | -      |
| Light beam        | 160        | degree |

### ● Other Parameter for Non-Dimmable Series :

|                     |             |    |
|---------------------|-------------|----|
| Lifespan            | 30,000      | hr |
| Working temperature | -20~+40     | °C |
| Storage temperature | -30~+60     | °C |
| Working humidity    | 30%~80%     | -  |
| Storage humidity    | 10%~80%     | -  |
| Weight              | 98          | g  |
| Inner box size      | 65×65×135   | mm |
| Package size        | 580×295×300 | mm |
| Lamp holder         | E27         | -  |



● Typical Lighting Distribution Curve

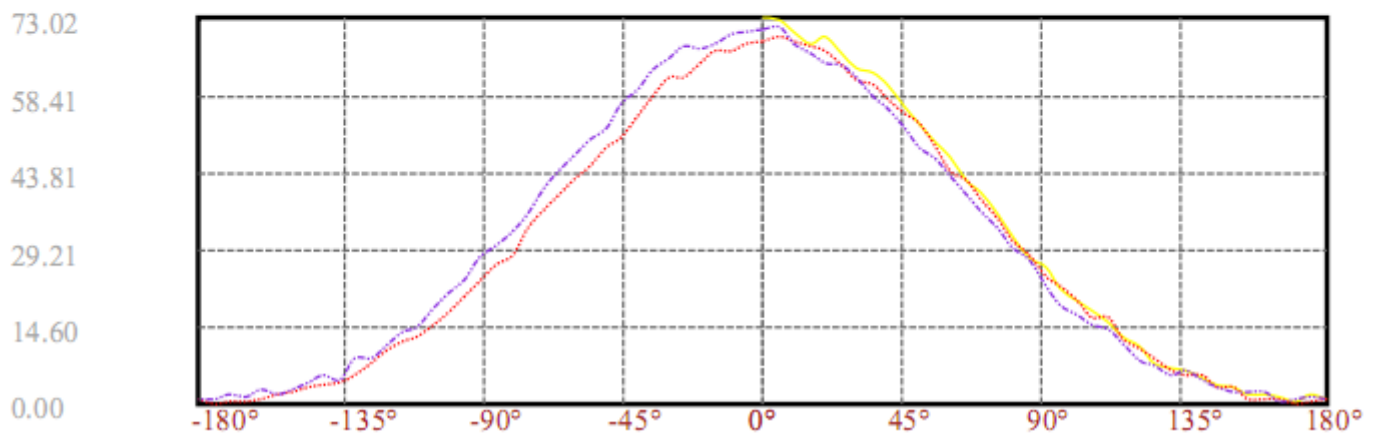
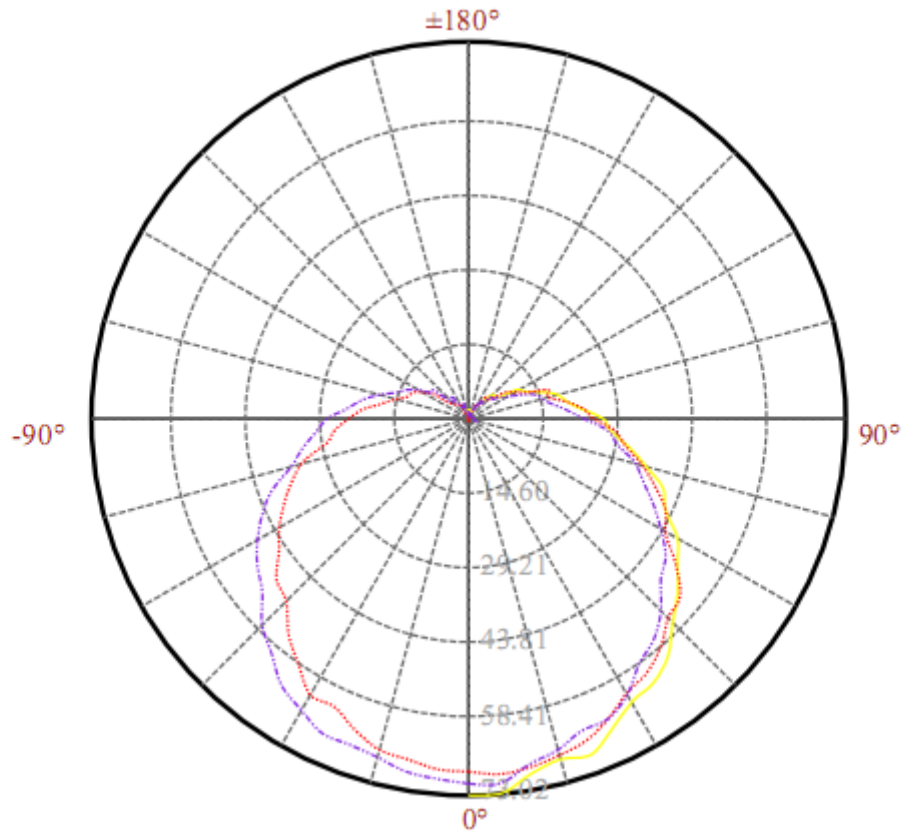



#### 4. External dimensions

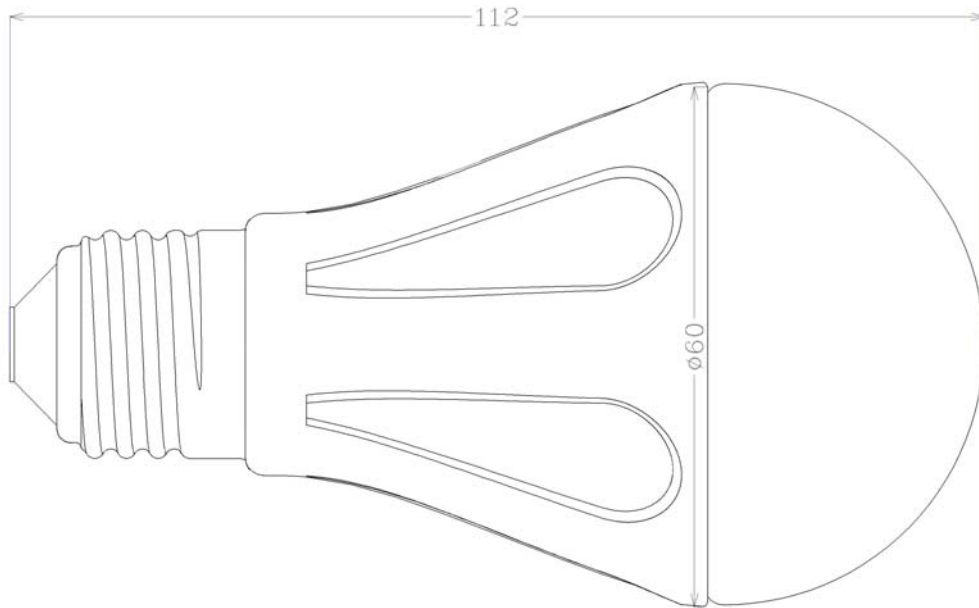

#### 5. Product Picture





## 6. Packing Size

|                    |               |            |
|--------------------|---------------|------------|
| Color Box          | 65×65×135mm   | 1pcs/1box  |
| Packing Carton (M) | 275×275×285mm | 32 pcs/CTN |
| Packing Carton (L) | 580×295×300mm | 64 pcs/CTN |

## 7. Instruction

### ✧ Environmental requirements

- Working Temperature: -20~40℃
- Working Humidity: 30%~80%
- Storage Temperature: -30~60℃
- Storage Humidity: 10%~80%

### ✧ Warnings and Cautions

- Please use the lamp under rated input voltage to ensure it working properly.
- Please install the lamps according to the instruction sheet.
- Please turn of the power supply while installing or dismantling the product for avoiding the risk of electric shock.
- Do not use in high humidity or dusty environment including but not limited to bathrooms, sauna rooms, polishing workshops.
- Not suitable for close light fixture
- Suitable in dimming line and light modulator,
- Do not stare at illuminant for a long time, eyes may get harm by high-intensity light source.
- Please contact the qualified electrician for repair service instead of take down or dismantle the lamp by yourself under the situations as follows:
  - a. Electronic components was splashed by rain or other liquid;
  - b. There is any abnormal smell, noise , or flash;
  - c. The lamp housing is broken and foreign objects enter inside.

## 8. Compensation Liability

- The information contained herein is presented only as a guide for the applications of our products.
- No responsibility is assumed by NATIONSTAR for any infringements of intellectual property or other infringements of the rights of third parties that may result from its use
- NATIONSTAR is committed to a process of continuous improvements of the quality and features of its products and reserves the right to make changes that result in such improvements.
- NATIONSTAR products are not intended for use in applications where extraordinarily high reliability is required to prevent the loss of human life or where failure could result in bodily injury.
- NATIONSTAR limits the extent of our liability to the initial component cost and will in the event of a failure replace a failed component or refund the purchase price at NATIONSTAR option.
- The above parameters are for reference only;. Please refer to the real product when you get it. If there is any revise later, please refer to the revised version.
- NationStar reserve the right to amend the data without any prior notification. Sorry for the inconvenience.